

ARI-Check valve, metallic sealing

ARI-CHECKO®-V -

Straight through with flanges

- TRB 801 Annex II No. 45 (except EN-JL1040)
- EN ISO 15848-1 / TA - Luft TÜV-Test-No. 973-10675245-10 C

Grey cast iron
SG iron
Cast steel
Fig. 003/303

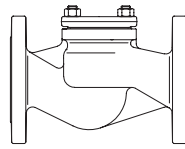

Page 2

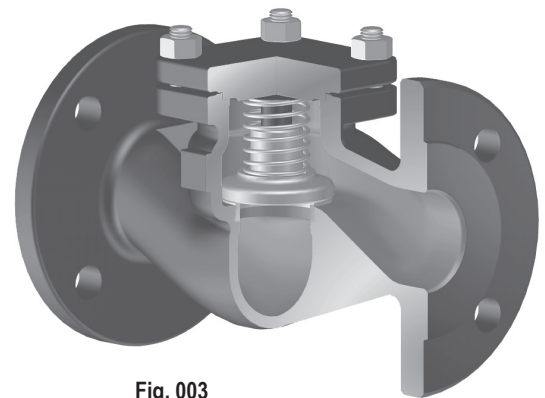

Fig. 003

ARI-CHECKO®-V -

Straight through with flanges

- TRB 801 Annex II No. 45
- EN ISO 15848-1 / TA - Luft TÜV-Test-No. 973-10675245-10 C

Forged steel
Fig. 003

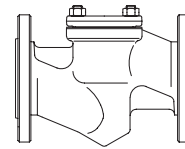

Page 3

ARI-CHECKO®-V -

Straight through with flanges

- TRB 801 Annex II No. 45
- EN ISO 15848-1 / TA - Luft TÜV-Test-No. 973-10675245-10 C

Stainless steel
Fig. 003

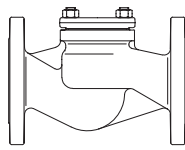

Page 4

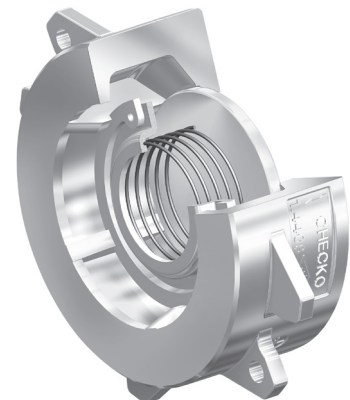

Fig. 001

ARI-CHECKO®-V -

Angle pattern with flanges

- TRB 801 Annex II No. 45 (except EN-JL1040)
- EN ISO 15848-1 / TA - Luft TÜV-Test-No. 973-10675245-10 C

Grey cast iron
SG iron
Cast steel
Fig. 004/304

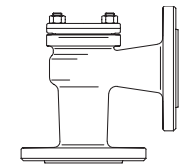

Page 5

ARI-CHECKO®-V -

Straight through with butt weld ends

- TRB 801 Annex II No. 45
- EN ISO 15848-1 / TA - Luft TÜV-Test-No. 973-10675245-10 C

Forged steel
Fig. 030

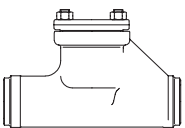

Page 6

ARI-CHECKO®-V -

Straight through with butt weld ends

- TRB 801 Annex II No. 45
- EN ISO 15848-1 / TA - Luft TÜV-Test-No. 973-10675245-10 C

Cast steel
Fig. 030

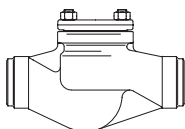

Page 7

ARI-CHECKO®-V -

Y-pattern with flanges

- TRB 801 Annex II No. 45
- EN ISO 15848-1 / TA - Luft TÜV-Test-No. 973-10675245-10 C

Stainless steel
Fig. 039

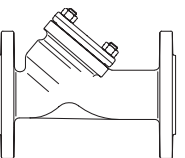

Page 8

ARI-CHECKO®-V -

Y-pattern with butt weld ends

- TRB 801 Annex II No. 45
- EN ISO 15848-1 / TA - Luft TÜV-Test-No. 973-10675245-10 C

Cast steel
Fig. 063

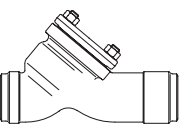

Page 9

ARI-CHECKO®-D -

Disc check valve in clamping version

- TRB 801 Annex II No. 45

Stainless steel
Fig. 001

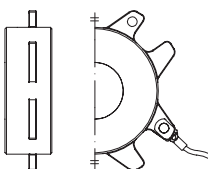

Page 10

Features:

- Solid plug / valve plate made of stainless material
- Solid seat made of stainless material
- Re-setting spring made of stainless steel
- Precise plug / valve plate guidance

Check valve - straight through with flanges (Grey cast iron, SG iron, Cast steel)

Figure	Nominal pressure	Material	Nominal diameter
10.003	PN6	EN-JL1040	DN15-200
12.003 / 12.303	PN16	EN-JL1040	DN15-300
22.003 / 22.003	PN16	EN-JS1049	DN15-350
23.003 / 23.303	PN25	EN-JS1049	DN15-150
34.003 / 34.303	PN25	1.0619+N	DN15-500
35.003 / 35.303	PN40	1.0619+N	DN15-500

Set pressure 0,1 bar
Fig. 303: Trim made of RG/MS:

CuZn35Ni3Mn2AlPb, CW710R code number 02

CuSn10-Cu, CC480K code number 03

(max. operating temperature: 180°C, code number acc. to DIN 86251)

Test: • EN ISO 15848-1 / TA - Luft TÜV-Test-No. 973-10675245-10 C

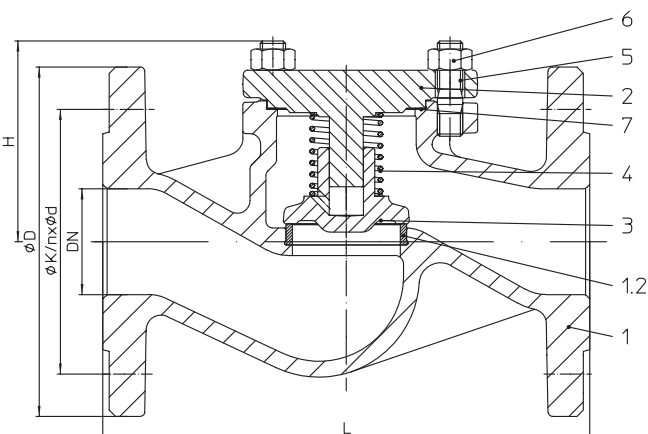

Parts								
Pos.	Sp.p.	Description	Fig. 10./12.003	Fig. 10./12.303	Fig. 22./23.003	Fig. 22./23.303	Fig. 34./35.003	Fig. 34./35.303
1		Body	EN-JL1040, EN-GJL-250		EN-JS1049, EN-GJS-400-18U-LT		GP240GH+N, 1.0619+N	
1.2		Seat ring	DN ≤50: X20Cr13+QT, 1.4021+QT DN >50: G19 9 Nb Si, 1.4551	CuSn10-Cu, CC480K code number 03	DN ≤50: X20Cr13+QT, 1.4021+QT DN >50: G19 9 Nb Si, 1.4551	CuSn10-Cu, CC480K code number 03	DN ≤50: X20Cr13+QT, 1.4021+QT DN >50: G19 9 Nb Si, 1.4551	CuSn10-Cu, CC480K code number 03
2		Cover	DN ≤20: EN-JS1049, EN-GJS-400-18U-LT DN >20 EN-JL1040, EN-GJL-250		EN-JS1049, EN-GJS-400-18U-LT		GP240GH+N, 1.0619+N	
3	x	Plug	DN ≤200: X20Cr13+QT, 1.4021+QT DN >200: P265 GH, 1.0425 / G19 9 Nb Si, 1.4551	CuZn35Ni3Mn 2AlPb, CW710R code nr. 02 CuSn10-Cu, CC480K code nr. 03	DN ≤200: X20Cr13+QT, 1.4021+QT DN >200: P265 GH, 1.0425 / G19 9 Nb Si, 1.4551	CuZn35Ni3Mn 2AlPb, CW710R code nr. 02 CuSn10-Cu, CC480K code nr. 03	DN ≤200: X20Cr13+QT, 1.4021+QT DN >200: P265 GH, 1.0425 / G19 9 Nb Si, 1.4551	CuZn35Ni3Mn 2AlPb, CW710R code nr. 02 CuSn10-Cu, CC480K code nr. 03
4		Spring	X10CrNi18-8, 1.4310		X10CrNi18-8, 1.4310			
5		Hexagon bolt	5.6		--			
5		Stud	--		25CrMo4, 1.7218			
6		Hexagon nut	--		C35E, 1.1181			
7	x	Gasket	Pure graphite (CrNi laminated with graphite)					
		L Spare parts						

DN	15	20	25	32	40	50	65	80	100	125	150	200	250	300	350	400	500
----	----	----	----	----	----	----	----	----	-----	-----	-----	-----	-----	-----	-----	-----	-----

Face-to-face dimension FTF series 1 according to DIN EN 558																	Standard-flange dimensions refer to page 11		
L	(mm)	130	150	160	180	200	230	290	310	350	400	480	600	730	850	980	1100	1350*	

Dimensions																			
H	(mm)	70	70	80	80	85	95	110	130	155	165	215	285	325	365	420	430	530	
Kvs-value	(m³/h)	5,7	7,8	11,8	17,9	27,5	48,0	77,6	109	168	251	389	664	1017	1446	2042	2725	4167	
Zeta-value	--	2,5	4,2	4,5	5,2	5,4	4,3	4,7	5,5	5,7	6,2	5,3	5,8	6,0	6,2	5,7	5,5	5,7	

Zeta-value ... range of tolerance for Kvs-values acc. to VDI/VDE 2173

Weights																			
Figure	(kg)	2,4	2,9	3,5	4,8	6,4	8,2	12,2	18,6	27	42	67	112	--	--	--	--	--	
10.003 / 303	(kg)	2,4	2,9	3,5	4,8	6,4	8,2	12,2	18,6	27	42	67	112	--	--	--	--	--	
12.003 / 303	(kg)	2,4	3	3,8	5,7	7,4	10,3	15,2	20,4	31	49	69	132	198	278	--	--	--	
22.003 / 303	(kg)	3,5	4	5	6	8	11	16	21	31	49	69	132	198	278	383	--	--	
23.003 / 303	(kg)	3,5	4	5	6	8	11	16	21	32	51	70	--	--	--	--	--	--	
34.003 / 303	(kg)	3,8	4,9	5,9	7,1	10,4	12,3	22,7	28,5	40	64	90	160	222	337	461	709	989	
35.003 / 303	(kg)	3,8	4,9	5,9	7,1	10,4	12,3	22,7	28,5	40	64	90	170	240	374	508	786	1044	

Information / restriction of technical rules need to be observed!

 Operating and installation instructions can be downloaded at www.ari-armaturen.com.

ARI-Valves of EN-JL1040 are not allowed to be operated in systems acc. to TRD 110.

A production permission acc. to TRB 801 No. 45 is available (acc. to TRB 801 No. 45 EN-JL1040 is not allowed.)

The engineer, designing a system or a plant, is responsible for the selection of the correct valve.

Resistance and fitness must be verified (contact manufacturer for information, refer to Product overview and Resistance list).

Check valve - straight through with flanges (Forged steel)

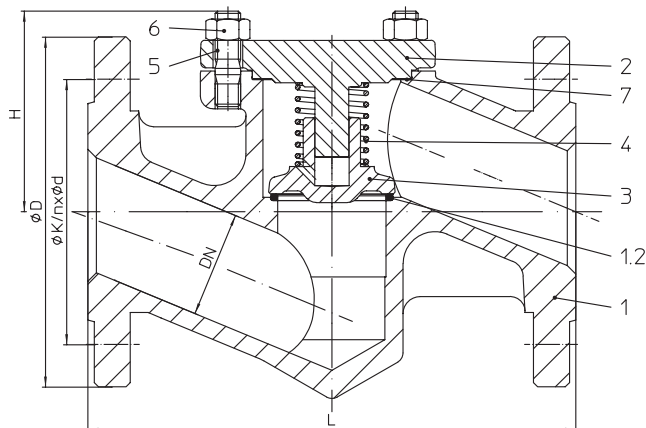

Figure	Nominal pressure	Material	Nominal diameter
45.003	PN40	1.0460	DN15-50

Set pressure 0,1 bar

Test: • EN ISO 15848-1 / TA - Luft TÜV-Test-No. 973-10675245-10 C

Parts			
Pos.	Sp.p.	Description	Fig. 45.003
1		Body	P250 GH, 1.0460
1.2		Seat ring	G19 9 Nb Si, 1.4551
2		Cover	P250 GH, 1.0460
3	x	Plug	X20Cr13+QT, 1.4021+QT
4		Spring	X10CrNi18-8, 1.4310
5		Stud	25CrMo4, 1.7218
6		Hexagon nut	C35E, 1.1181
7	x	Gasket	Pure graphite (CrNi laminated with graphite)
L Spare parts			

DN	15	20	25	32	40	50
----	----	----	----	----	----	----

Face-to-face dimension FTF series 1 according to DIN EN 558		Standard-flange dimensions refer to page 11					
L	(mm)	130	150	160	180	200	230

Dimensions							
H	(mm)	87	89	97	103	95	95
Kvs-value	(m³/h)	3,3	5,5	9,2	15	29,3	36
Zeta-value	--	7,4	8,4	7,4	7,4	4,8	7,7
Zeta-value ... range of tolerance for Kvs-values acc. to VDI/VDE 2173							

Weights							
45.003	(kg)	3,2	4,5	4,6	7,3	9,5	12

Information / restriction of technical rules need to be observed!

 Operating and installation instructions can be downloaded at www.ari-armaturen.com.

A production permission acc. to TRB 801 No. 45 is available.

The engineer, designing a system or a plant, is responsible for the selection of the correct valve.

Resistance and fitness must be verified (contact manufacturer for information, refer to Product overview and Resistance list).

Check valve - straight through with flanges (Stainless steel)

Figure	Nominal pressure	Material	Nominal diameter
52.003	PN16	1.4408	DN65-200
54.003	PN25	1.4408	DN15-200
55.003	PN40	1.4408	DN15-200

Set pressure 0,1 bar

Test: • EN ISO 15848-1 / TA - Luft TÜV-Test-No. 973-10675245-10 C

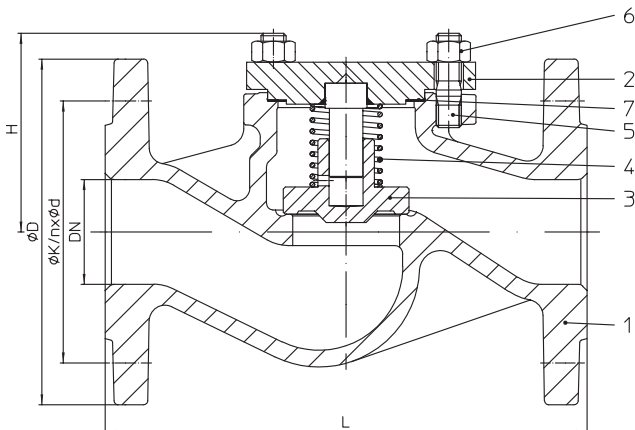

Parts			
Pos.	Sp.p.	Description	Fig. 52./54./55.003
1		Body	GX5CrNiMo19-11-2, 1.4408
2		Cover	X6CrNiMoTi17-12-2, 1.4571
3	x	Plug	X6CrNiMoTi17-12-2, 1.4571
4		Spring	X10CrNi18-8, 1.4310
5		Stud	A4-70
6		Hexagon nut	A4
7	x	Gasket	Pure graphite (CrNi laminated with graphite)
L Spare parts			

DN	15	20	25	32	40	50	65	80	100	125	150	200	250	300	350	400	500
Face-to-face dimension FTF series 1 according to DIN EN 558																	
Standard-flange dimensions refer to page 11																	
L	(mm)	130	150	160	180	200	230	290	310	350	400	480	600	on request			
Dimensions																	
H	(mm)	70	70	80	80	85	95	110	130	155	165	215	285	on request			
Kvs-value	(m³/h)	5,7	7,8	11,8	17,9	27,5	48,0	77,6	109	168	251	389	664	on request			
Zeta-value	--	2,5	4,2	4,5	5,2	5,4	4,3	4,7	5,5	5,7	6,2	5,3	5,8				
Zeta-value ... range of tolerance for Kvs-values acc. to VDI/VDE 2173																	
Weights																	
52.003	(kg)	--	--	--	--	--	--	22,5	28,5	38	61	87	154	on request			
54.003	(kg)	3,8	4,9	5,9	7,1	10	12	22,5	28,5	40	64	90	160	on request			
55.003	(kg)	3,8	4,9	5,9	7,1	10	12	22,5	28,5	40	64	90	170	on request			

Information / restriction of technical rules need to be observed!

 Operating and installation instructions can be downloaded at www.ari-armaturen.com.

A production permission acc. to TRB 801 No. 45 is available.

The engineer, designing a system or a plant, is responsible for the selection of the correct valve.

Resistance and fitness must be verified (contact manufacturer for information, refer to Product overview and Resistance list).

Check valve - angle pattern with flanges (Grey cast iron, SG iron, Cast steel)

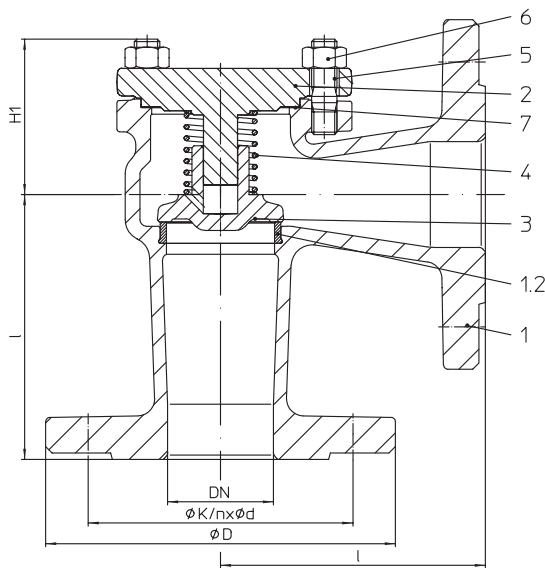

Figure	Nominal pressure	Material	Nominal diameter
12.004 / 12.304	PN16	EN-JL1040	DN15-300
22.004 / 22.304	PN16	EN-JS1049	DN15-350
23.004 / 23.304	PN25	EN-JS1049	DN15-150
34.004 / 34.304	PN25	1.0619+N	DN15-500
35.004 / 35.304	PN40	1.0619+N	DN15-500

Set pressure 0,1 bar

Fig. 304: Trim made of RG/MS:

CuZn35Ni3Mn2AlPb, CW710R code number 02

CuSn10-Cu, CC480K code number 03

(max. operating temperature: 180°C, code number acc. to DIN 86251)

Test: • EN ISO 15848-1 / TA - Luft TÜV-Test-No. 973-10675245-10 C

Parts								
Pos.	Sp.p.	Description	Fig. 12.004	Fig. 12.304	Fig. 22./23.004	Fig. 22./23.304	Fig. 34./35.004	Fig. 34./35.304
1		Body	EN-JL1040, EN-GJL-250		EN-JS1049, EN-GJS-400-18U-LT		GP240GH+N, 1.0619+N	
1.2		Seat ring	DN ≤50: X20Cr13+QT, 1.4021+QT DN >50: G19 9 Nb Si, 1.4551	CuSn10-Cu, CC480K code number 03	DN ≤50: X20Cr13+QT, 1.4021+QT DN >50: G19 9 Nb Si, 1.4551	CuSn10-Cu, CC480K code number 03	DN ≤50: X20Cr13+QT, 1.4021+QT DN >50: G19 9 Nb Si, 1.4551	CuSn10-Cu, CC480K code number 03
2		Cover	DN ≤20: EN-JS1049, EN-GJS-400-18U-LT DN >20 EN-JL1040, EN-GJL-250		EN-JS1049, EN-GJS-400-18U-LT		GP240GH+N, 1.0619+N	
3	x	Plug	DN ≤200: X20Cr13+QT, 1.4021+QT DN >200: P265 GH, 1.0425 / G19 9 Nb Si, 1.4551	CuSn10-Cu, CC480K code number 03	DN ≤200: X20Cr13+QT, 1.4021+QT DN >200: P265 GH, 1.0425 / G19 9 Nb Si, 1.4551	CuSn10-Cu, CC480K code number 03	DN ≤200: X20Cr13+QT, 1.4021+QT DN >200: P265 GH, 1.0425 / G19 9 Nb Si, 1.4551	CuSn10-Cu, CC480K code number 03
4		Spring	X10CrNi18-8, 1.4310		X10CrNi18-8, 1.4310			
5		Hexagon bolt	5.6		--			
5		Stud	--		25CrMo4, 1.7218			
6		Hexagon nut	--		C35E, 1.1181			
7	x	Gasket	Pure graphite (CrNi laminated with graphite)					
		L Spare parts						

DN	15	20	25	32	40	50	65	80	100	125	150	200	250	300	350	400	500
----	----	----	----	----	----	----	----	----	-----	-----	-----	-----	-----	-----	-----	-----	-----

Face-to-face dimension CTF series 8 according to DIN EN 558																	Standard-flange dimensions refer to page 11		
l	(mm)	90	95	100	105	115	125	145	155	175	200	225	275	325	375	425	475	525*	

* Face-to-face dimension acc. to ARI-works standard

Dimensions																		
H1	(mm)	40	35	45	45	55	60	65	95	105	120	150	195	220	240	300	310	380
Kvs-value	(m³/h)	4,8	8,5	13	22	34	53	88	138	216	331	469	832	1315	1876	2553	3406	5207
Zeta-value	--	3,5	3,5	3,7	3,5	3,5	3,6	3,7	3,4	3,4	3,6	3,7	3,7	3,6	3,7	3,7	3,5	3,7
Zeta-value ... range of tolerance for Kvs-values acc. to VDI/VDE 2173																		

Weights																		
12.004 / 304	(kg)	3	3,5	4	6	8	10	14	19	25	45	70	112	179	248	345	--	--
22.004 / 304	(kg)	3	3,5	4	6	8	10	14	19	25	45	70	112	179	248	345	--	--
23.004 / 304	(kg)	3	3,5	4,1	6	8	10	14	20	29	49	73	on request					
34.004 / 304	(kg)	4,2	4,9	5	7,6	10	12	24,5	28,5	42	55	90	145	170	225	383	623	870
35.004 / 304	(kg)	4,2	4,9	5	7,6	10	12	24,5	28,5	42	55	90	155	188	262	430	700	925

Information / restriction of technical rules need to be observed!

 Operating and installation instructions can be downloaded at www.ari-armaturen.com.

ARI-Valves of EN-JL1040 are not allowed to be operated in systems acc. to TRD 110.

A production permission acc. to TRB 801 No. 45 is available (acc. to TRB 801 No. 45 EN-JL1040 is not allowed.)

The engineer, designing a system or a plant, is responsible for the selection of the correct valve.

Resistance and fitness must be verified (contact manufacturer for information, refer to Product overview and Resistance list).

Check valve - straight through with butt weld ends (Forged steel)

Figure	Nominal pressure	Material	Nominal diameter
45.030	PN40	1.0460	DN15-50

Set pressure 0,1 bar

Butt weld ends according to DIN EN 12627 Fig. 4 (refer to page 12)

Test: • EN ISO 15848-1 / TA - Luft TÜV-Test-No. 973-10675245-10 C

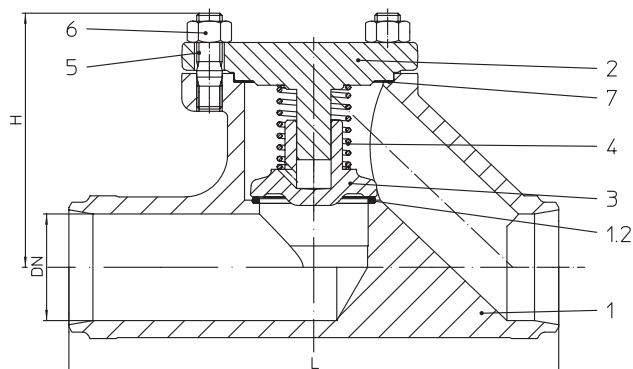

Parts			
Pos.	Sp.p.	Description	Fig. 45.030
1		Body	P250 GH, 1.0460
1.2		Seat ring	G19 9 Nb Si, 1.4551
2		Cover	P250 GH, 1.0460
3	x	Plug	X20Cr13+QT, 1.4021+QT
4		Spring	X10CrNi18-8, 1.4310
5		Stud	25CrMo4, 1.7218
6		Hexagon nut	C35E, 1.1181
7	x	Gasket	Pure graphite (CrNi laminated with graphite)
L Spare parts			

DN	15	20	25	32	40	50
----	----	----	----	----	----	----

Face-to-face dimension ETE series 1 according to DIN EN 12982							
L	(mm)	130	150	160	180	200	230

Dimensions							
H	(mm)	70	70	80	80	85	95
Kvs-value	(m³/h)	3,3	5,5	9,2	15	29,3	36
Zeta-value	--	7,4	8,4	7,4	7,4	4,8	7,7
Zeta-value ... range of tolerance for Kvs-values acc. to VDI/VDE 2173							

Weights							
45.030	(kg)	3	3,9	4,6	5,3	8,5	9,7

Information / restriction of technical rules need to be observed!

 Operating and installation instructions can be downloaded at www.ari-armaturen.com.

A production permission acc. to TRB 801 No. 45 is available.

The engineer, designing a system or a plant, is responsible for the selection of the correct valve.

Resistance and fitness must be verified (contact manufacturer for information, refer to Product overview and Resistance list).

Check valve - straight through with butt weld ends (Cast steel)

Figure	Nominal pressure	Material	Nominal diameter
35.030	PN40	1.0619+N	DN65-300

Set pressure 0,1 bar

 Butt weld ends according to DIN EN 12627 Fig. 4 (refer to page 12)
 alternative: DN 65-200 with shoed ends of P235GH

Test: • EN ISO 15848-1 / TA - Luft TÜV-Test-No. 973-10675245-10 C

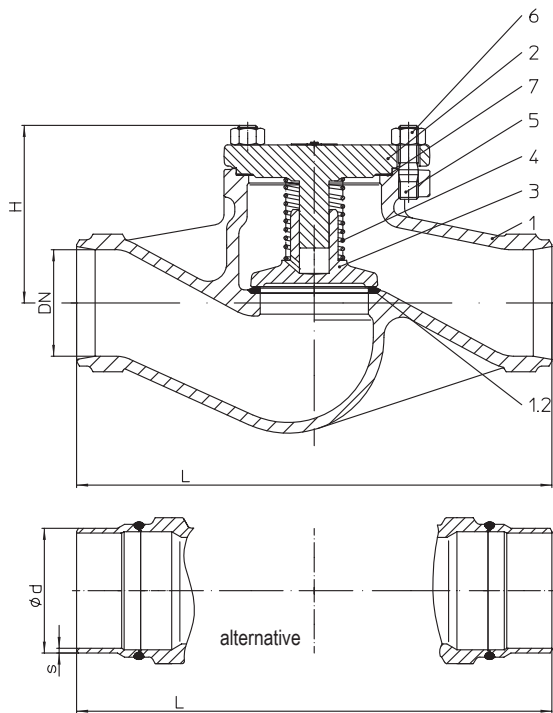
Parts			
Pos.	Sp.p.	Description	Fig. 35.030
1		Body	GP240GH+N, 1.0619+N
1.2		Seat ring	DN ≤50: X20Cr13+QT, 1.4021+QT DN >50: G19 9 Nb Si, 1.4551
2		Cover	GP240GH+N, 1.0619+N
3	x	Plug	DN ≤200: X20Cr13+QT, 1.4021+QT DN >200: P265 GH, 1.0425 / G19 9 Nb Si, 1.4551
4		Spring	X10CrNi18-8, 1.4310
5		Stud	25CrMo4, 1.7218
6		Hexagon nut	C35E, 1.1181
7	x	Gasket	Pure graphite (CrNi laminated with graphite)
L Spare parts			

DN	65	80	100	125	150	200	250	300
----	----	----	-----	-----	-----	-----	-----	-----

Face-to-face dimension ETE series 1 according to DIN EN 12982									
L	(mm)	290	310	350	400	480	600	730	850

Dimensions									
H	(mm)	110	130	155	165	215	285	325	365
Kvs-value	(m³/h)	77,6	109	168	251	389	664	1017	1446
Zeta-value	--	4,7	5,5	5,7	6,2	5,3	5,8	6	6,2

Zeta-value ... range of tolerance for Kvs-values acc. to VDI/VDE 2173

Weights									
35.030	(kg)	19,2	24	34	56	80	152	222	300

Information / restriction of technical rules need to be observed!

 Operating and installation instructions can be downloaded at www.ari-armaturen.com.

A production permission acc. to TRB 801 No. 45 is available.

The engineer, designing a system or a plant, is responsible for the selection of the correct valve.

Resistance and fitness must be verified (contact manufacturer for information, refer to Product overview and Resistance list).

Check valve - Y-pattern with flanges (Stainless steel)

Figure	Nominal pressure	Material	Nominal diameter
52.039	PN16	1.4408	DN15-200
54.039	PN25	1.4408	DN15-200
55.039	PN40	1.4408	DN15-200

Set pressure 0,1 bar

Test: • EN ISO 15848-1 / TA - Luft TÜV-Test-No. 973-10675245-10 C

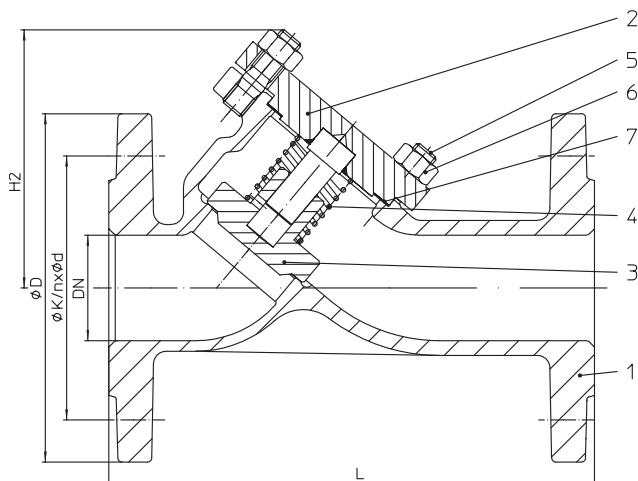

Parts			
Pos.	Sp.p.	Description	Fig. 52./54./55.039
1		Body	GX5CrNiMo19-11-2, 1.4408
2		Cover	X6CrNiMoTi17-12-2, 1.4571
3	x	Plug	X6CrNiMoTi17-12-2, 1.4571
4		Spring	X10CrNi18-8, 1.4310
5		Stud	A4-70
6		Hexagon nut	A4
7	x	Gasket	Pure graphite (CrNi laminated with graphite)
L Spare parts			

DN	15	20	25	32	40	50	65	80	100	125	150	200
----	----	----	----	----	----	----	----	----	-----	-----	-----	-----

Face-to-face dimension FTF series 1 according to DIN EN 558													Standard-flange dimensions refer to page 11	
L	(mm)	130	150	160	180	200	230	290	310	350	400	480	600	

Dimensions													
H2	(mm)	75	75	90	90	110	110	135	160	200	245	300	390
Kvs-value	(m³/h)	6,7	8,5	14,9	18,8	33	50,9	78,5	124	181	302	450	791
Zeta-value	--	1,8	3,5	2,8	4,7	3,8	3,9	4,6	4,3	4,9	4,3	4	4,1
Zeta-value ... range of tolerance for Kvs-values acc. to VDI/VDE 2173													

Weights													
52.039	(kg)	3,1	3,8	5	7	8,4	11	15,5	22	29	42	65	119
54.039	(kg)	3,1	3,8	5	7	8,4	11	15,5	22	31	45	68	125
55.039	(kg)	3,1	3,8	5	7	8,4	11	15,5	22	31	45	68	135

Information / restriction of technical rules need to be observed!

 Operating and installation instructions can be downloaded at www.ari-armaturen.com.

A production permission acc. to TRB 801 No. 45 is available.

The engineer, designing a system or a plant, is responsible for the selection of the correct valve.

Resistance and fitness must be verified (contact manufacturer for information, refer to Product overview and Resistance list).

Check valve - Y-pattern with butt weld ends (Cast steel)

Figure	Nominal pressure	Material	Nominal diameter
35.063	PN40	1.0619+N	DN15-250

Set pressure 0,1 bar

Butt weld ends according to DIN EN 12627 Fig. 4 (refer to page 12)

Test: • EN ISO 15848-1 / TA - Luft TÜV-Test-No. 973-10675245-10 C

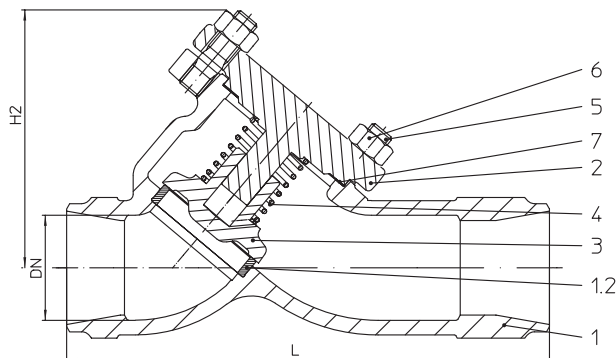
Parts			
Pos.	Sp.p.	Description	Fig. 35.063
1		Body	GP240GH+N, 1.0619+N
1.2		Seat ring	DN ≤80: X20Cr13+QT, 1.4021+QT DN >80: G19 9 Nb Si, 1.4551
2		Cover	GP240GH+N, 1.0619+N
3	x	Plug	DN ≤200: X20Cr13+QT, 1.4021+QT DN >200: P265 GH, 1.0425 / G19 9 Nb Si, 1.4551
4		Spring	X10CrNi18-8, 1.4310
5		Stud	25CrMo4, 1.7218
6		Hexagon nut	C35E, 1.1181
7	x	Gasket	Pure graphite (CrNi laminated with graphite)
L Spare parts			

DN	15	20	25	32	40	50	65	80	100	125	150	200	250	300
----	----	----	----	----	----	----	----	----	-----	-----	-----	-----	-----	-----

Face-to-face dimension ETE series 1 according to DIN EN 12982															
L	(mm)	130	150	160	180	200	230	290	310	350	400	480	600	730	on request

Dimensions															
H2	(mm)	75	75	90	90	110	110	135	160	200	245	300	390	470	on request
Kvs-value	(m³/h)	6,7	8,5	14,9	18,8	33	50,9	78,5	124	181	302	450	791	1230	
Zeta-value	--	1,8	3,5	2,8	4,7	3,8	3,9	4,6	4,3	4,9	4,3	4	4,1	4,1	

Zeta-value ... range of tolerance for Kvs-values acc. to VDI/VDE 2173

Weights															
35.063	(kg)	2,3	2,4	3,1	3,4	4,5	5,7	9,8	13,3	20	25,5	43,8	140	162	on request

Information / restriction of technical rules need to be observed!

 Operating and installation instructions can be downloaded at www.ari-armaturen.com.

A production permission acc. to TRB 801 No. 45 is available.

The engineer, designing a system or a plant, is responsible for the selection of the correct valve.

Resistance and fitness must be verified (contact manufacturer for information, refer to Product overview and Resistance list).

Disc check valve in clamping version (Stainless steel)

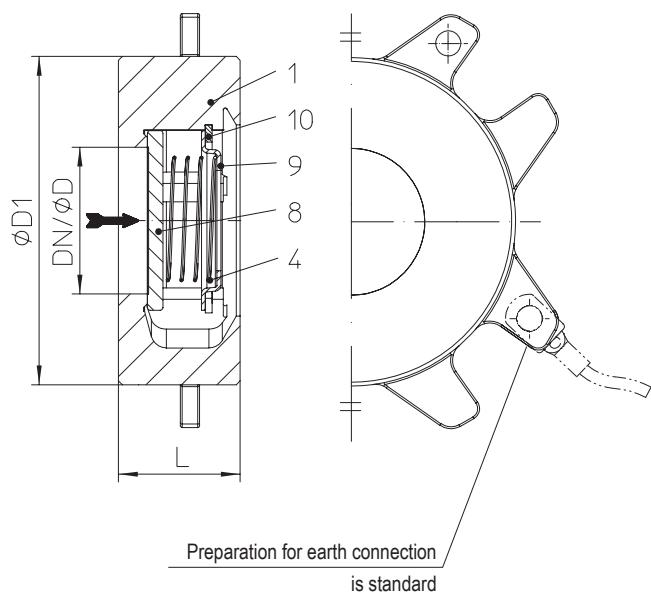

Figure	Nominal pressure	Material	Nominal diameter
55.001	PN40	1.4408	DN15-100
	DN125-350 on request.		

Set pressure 0,02 barg
Shut off class Valve plate

- standard:
- metallic sealing
Leakage rate BN2/BO3 acc. to DIN 3230-3
(Leakage rate D acc. to DIN EN 12266-1 fulfilled)
- optional:
- EPDM-soft sealing (max. 120°C)
Leakage rate A acc. to DIN EN 12266-1
 - NBR-soft sealing (max. 80°C)
Leakage rate A acc. to DIN EN 12266-1
 - FPM (Viton)-soft sealing (max. 150°C)
Leakage rate A acc. to DIN EN 12266-1
(not for hot water useable)

Parts			
Pos.	Sp.p.	Description	Fig. 55.001
1		Body	GX5CrNiMo19-11-2, 1.4408
4		Spring	X10CrNi18-8, 1.4310
8	x	Valve plate	X6CrNiMoTi17-12-2, 1.4571
9		Spring plate	X6CrNiMoTi17-12-2, 1.4571
10		Retaining ring	X39CrMo17-1+QT, 1.4122+QT
L Spare parts			

DN	15	20	25	32	40	50	65	80	100
----	----	----	----	----	----	----	----	----	-----

Face-to-face dimension FTF series 49 acc. to DIN EN 558										
L	(mm)	16	19	22	28	31,5	40	46	50	60

Dimensions										
ØD (acc. to DIN EN 14341)	(mm)	13	19	25	31	38	50	63	76	100
ØD1	(mm)	45	55	65	75	85	98	118	134	154
Kvs-value	(m³/h)	4,4	7,1	12	19,5	25	46	69	87	122
Zeta-value	--	4,18	5	4,33	4,4	6,54	4,72	6	8,64	10,73
Zeta-value ... range of tolerance for Kvs-values acc. to VDI/VDE 2173										

Weights										
55.001	(kg)	0,14	0,32	0,42	0,67	0,92	1,32	1,9	2,5	3,7

Information / restriction of technical rules need to be observed!

Operating and installation instructions can be downloaded at www.ari-armaturen.com.

A production permission acc. to TRB 801 No. 45 is available.

The engineer, designing a system or a plant, is responsible for the selection of the correct valve.

Resistance and fitness must be verified (contact manufacturer for information, refer to Product overview and Resistance list).

DN	15	20	25	32	40	50	65	80	100	125	150	200	250	300	350	400	500		
Standard-flange dimensions																			
Flanges acc. to DIN EN 1092-1/-2 (Flange holes / -thickness tolerances acc. to DIN 2533/2544/2545)																			
PN6	ØD	(mm)	80	90	100	120	130	140	160	190	210	240	265	320	--	--	--	--	
	ØK	(mm)	55	65	75	90	100	110	130	150	170	200	225	280	--	--	--	--	
	n x Ød	(mm)	4x11	4x11	4x11	4x14	4x14	4x14	4x14	4x18	4x18	8x18	8x18	8x18	--	--	--	--	
PN16	ØD	(mm)	95	105	115	140	150	165	185	200	220	250	285	340	405	460	520	580	715
	ØK	(mm)	65	75	85	100	110	125	145	160	180	210	240	295	355	410	470	525	650
	n x Ød	(mm)	4x14	4x14	4x14	4x18	4x18	4x18	4x18 ¹⁾	8x18	8x18	8x18	8x22	12x22	12x26	12x26	16x26	16x30	20x33
PN25	ØD	(mm)	95	105	115	140	150	165	185	200	235	270	300	360	425	485	555	620	730
	ØK	(mm)	65	75	85	100	110	125	145	160	190	220	250	310	370	430	490	550	660
	n x Ød	(mm)	4x14	4x14	4x14	4x18	4x18	4x18	8x18	8x18	8x22	8x26	8x26	12x26	12x30	16x30	16x33	16x36	20x36
PN40	ØD	(mm)	95	105	115	140	150	165	185	200	235	270	300	375	450	515	580	660	755
	ØK	(mm)	65	75	85	100	110	125	145	160	190	220	250	320	385	450	510	585	670
	n x Ød	(mm)	4x14	4x14	4x14	4x18	4x18	4x18	8x18	8x18	8x22	8x26	8x26	12x30	12x33	16x33	16x36	16x39	20x42

¹⁾ also with 8 bore holes acc. to DIN EN 1092-1/-2 possible.

Pressure-temperature-ratings Intermediate values for max. permissible operational pressures can be determined by linear interpolation of the given temperature / pressure chart.

acc. to DIN EN 1092-2			-60°C to <-10°C ¹⁾	-10°C to 120°C	150°C	200°C	250°C	300°C	350°C	400°C	450°C
EN-JL1040	6	(bar)	--	6	5,4	4,8	4,2	3,6	--	--	--
EN-JL1040	16	(bar)	--	16	14,4	12,8	11,2	9,6	--	--	--
EN-JS1049	16	(bar)	on request	16	15,5	14,7	13,9	12,8	11,2	--	--
EN-JS1049	25	(bar)	on request	25	24,3	23	21,8	20	17,5	--	--

acc. to manufacturers standard			-60°C to <-10°C ¹⁾	-10°C to 120°C	150°C	200°C	250°C	300°C	350°C	400°C	450°C
1.0619+N	25	(bar)	18,7	25	23,9	22	20	17,2	16	14,8	8,2
1.0619+N	40	(bar)	30	40	38,1	35	32	28	25,7	23,8	13,1
1.0460	25	(bar)	18,7	25	23,9	22	20	17,2	16	14,8	10
1.0460	40	(bar)	30	40	38,1	35	32	28	25,7	23,8	16

acc. to DIN EN 1092-1			-60°C to <-10°C ¹⁾	-10°C to 100°C	150°C	200°C	250°C	300°C	350°C	400°C	450°C
1.4408	16	(bar)	16	16	14,5	13,4	12,7	11,8	11,4	10,9	--
1.4408	25	(bar)	25	25	22,7	21	19,8	18,5	17,8	17,1	--
1.4408	40	(bar)	40	40	36,3	33,7	31,8	29,7	28,5	27,4	--

¹⁾ Studs and nuts made of A4-70 (at temperatures below -10°C)

CHECKO®-V: Plug design

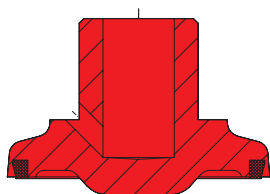

Soft sealing plug
Max. operating temperature 200°C at PTFE + 25% carbon

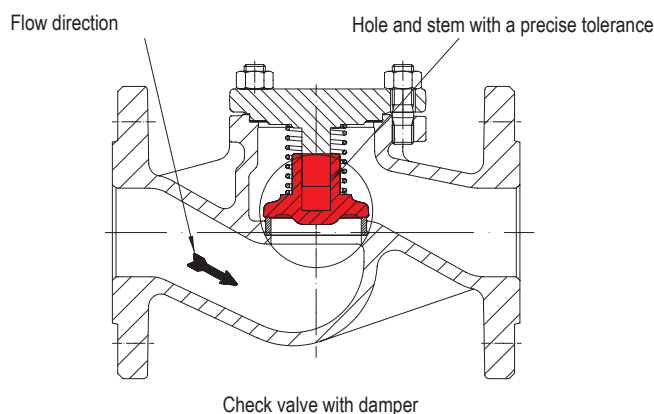

In special applications, like high flow turbulences, check valves with damper should be used:

- if check valves are mounted directly by centrifuged pumps;
- behind pressure reduction stations;
- behind pipe elbows;
- in compact plants;
- if expansion joints are missing;
- if the pump is not mounted on a damper;
- if there is no flow stabilizing pipe dimension;
- if there is no start-up bypass line;
- when chosen valve diameter to large.

Working principle

The precise tolerance between shaft and plug hole prevents an abrupt displacement of medium out of the plug.

L = Face-to-face dimension

Edge shaping acc. to DIN EN 25817

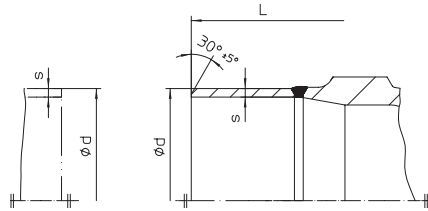
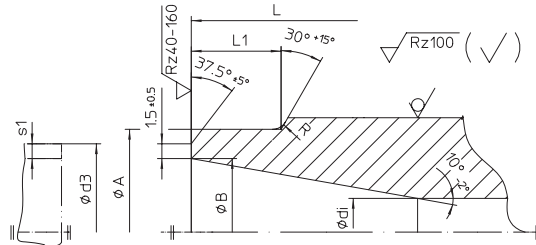

DN	15	20	25	32	40	50	65	80	100	125	150	200	250	300	350	400
----	----	----	----	----	----	----	----	----	-----	-----	-----	-----	-----	-----	-----	-----

Butt weld ends according to DIN EN 12627

L	(mm)	130	150	160	180	200	230	290	310	350	400	480	600	730	850	980	1100
ØA	(mm)	22	28	35	44	50	62	77	91	117	144	172	223	278	329	362	413
ØB	(mm)	17,3	22,3	28,5	37,2	43,1	53,9	68,9	80,9	104,3	130,7	157,1	204,9	257,	307,9	338,	384,4
Ødi	(mm)	15	20	25	32	40	50	65	80	100	125	150	200	250	300	330	375
R	(mm)	3	3	3	3	3	3	3	3	3	3	3	5	5	5	5	5
L1 (similar)	(mm)	10	10	10	10	10	10	10	12	14	18	20	20	25	33	45	45
Ød3	(mm)	21,3	26,9	33,7	42,4	48,3	60,3	76,1	88,9	114,3	139,7	168,3	219,1	273	323,9	355,6	406,4
s1	(mm)	2	2,3	2,6	2,6	2,6	3,2	3,6	4	5	4,5	5,6	7,1	8	8	8,8	11

Face-to-face dimension acc. to DIN EN 12982 ETE-1

Butt weld ends according to DIN EN 12627 Fig. 4

Weld joint according to DIN EN 29692 code number 1.3.3

The material used for ARI valves with butt weld ends are:

 GP240GH+N, 1.0619+N acc. to DIN EN 10213-2,
 P250 GH, 1.0460 acc. to DIN EN 10222-2.

DN	15	20	25	32	40	50	65	80	100	125	150	200	250	300	350	400
----	----	----	----	----	----	----	----	----	-----	-----	-----	-----	-----	-----	-----	-----

Shoed ends of P235GH (Pipe connection Δ welding neck flanges)

Ød	(mm)	--	--	--	--	--	76,1	88,9	114,3	139,7	168,3	219,1	--	--	--	--
Øs	(mm)	--	--	--	--	--	2,9	3,2	3,6	4	4,5	6,3	--	--	--	--

The material used for ARI valves with shoed ends (DN 65-200) P235GH according to DIN EN 10216-2.

Based on our experience we recommend electric welding process for connecting valves or strainers with tubes or with each other.

Lime based electrodes with an appropriate composite material should be used as filler material for welding.

Gas welding should be avoided.

Because of the different material compositions and wall thickness of the steam traps and the pipe gas welding shall not be applied. Quenching cracks and coarse grain structure may develop.

Please indicate when ordering:

- Figure-No.
- Nominal pressure
- Nominal diameter
- Special design / accessories

Example:

Figure 35.003; nominal pressure PN40; nominal diameter DN100.

Technology for the Future.
 GERMAN QUALITY VALVES

 ARI-Armaturen Albert Richter GmbH & Co. KG, D-33756 Schloß Holte-Stukenbrock,
 Tel. +49 52 07 / 994-0, Telefax +49 52 07 / 994-158 or 159 Internet: <http://www.ari-armaturen.com> E-mail: info.vertrieb@ari-armaturen.com